



# QWM 1970

UHF True Diversity  
Wireless Microphone System

## Instruction Manual



# CONTENTS

1. Introduction
2. Receiver Features
3. Receiver Display & Operation
6. Handheld Features
7. Bodypack Features
8. Quick Start Guide
9. Technical Specifications
10. Warnings & Correct Usage
11. UK Frequency Information
12. User Notes

Thank you for purchasing this Q-Audio product, we are sure that it will serve you for many years to come.

To optimise the performance of this product, please read these operating instructions carefully to familiarise yourself with the basic operations of this unit. Please retain them for future reference. This unit has been tested at the factory before being shipped to you.

To prevent or reduce the risk of electrical shock or fire, do not expose the unit to rain or moisture. To prevent a fire hazard, do not expose the unit to any naked flame sources. Unplug this apparatus during lightning storms or if it is unlikely to be used for long periods of time.

When installing the unit, please ensure you leave enough space around the unit for ventilation. Slots and openings in the unit are provided for ventilation to ensure reliable operation of the product and to protect it from overheating.

To prevent fire hazard, the openings should never be blocked or covered.

The unit is mains powered, always handle the power cable by the plug. Never pull out the plug by pulling on the cable. Never touch the power cable when your hands are wet as this could cause an electric shock. Do not tie a knot in the cable. The power cable should be placed such that it is not likely to be stepped on. A damaged power cable can cause a fire or give you an electrical shock. Check the power cord periodically, if you ever find that it is damaged, replace it before using the unit again. Contact your retailer for a replacement.

The voltage of the available power supply differs according to country or region. Be sure that the power supply voltage of the area where this unit is to be used meets the required written on the unit.

The lightning flash symbol inside a triangle is to alert the user to the presence of high voltage within the unit's enclosure that may be of sufficient power to constitute a risk of electrical shock to persons.

Caution: to prevent the risk of electric shock, do not attempt to open the unit. No user-serviceable parts inside. Refer all servicing to qualified service personnel.

The exclamation mark inside a triangle is intended to alert the user to the presence of important operating and maintenance instructions in the literature accompanying the appliance.

Select the installation location of your unit carefully. Avoid placing it in direct sunlight or locations subject to vibration and excessive dust. Do not use the unit where there are extremes in temperature (below 41°F / 5°C or exceeding 95°F / 35°C).

Unpacking and safety Please unpack your new product carefully. Your new product should reach you in perfect condition. Please check that no damage has occurred during transit. If any damage is found, do not operate your unit. Please contact the retailer you purchased it from immediately. If there is any damage to the mains cable do not use the device. Always disconnect the unit from the mains supply when carrying out any cleaning of the unit.

## Manufacturer declarations

In compliance with the following requirements: RoHS Directive (2002/95/EU) and WEEE Directive (2002/96/EU), and Battery Directive (2006/66/EU). If this product is ever no longer functional please take it to a recycling plant for environmentally friendly disposal. Any supplied batteries can also be recycled.

## CE declaration of conformity

R&TTE Directive (1999/5/EU), EMC Directive (2004/108/EU), Low Voltage Directive (2006/95/EU).

The declarations are available on application from [info@q-audio.co.uk](mailto:info@q-audio.co.uk)

Before putting device into operation, please observe the respective country-specific regulations.

Due to continuous product development, please ensure that you have downloaded the latest instruction manual for this product from the Q-Audio website

Telephone: (+44) (0) 203 598 5164 • Email: [info@q-audio.co.uk](mailto:info@q-audio.co.uk) • Web: [www.q-audio.co.uk](http://www.q-audio.co.uk)

If this product is ever no longer functional please take it to a recycling plant for environmentally friendly disposal.

Due to continuous product development, specifications and appearance are subject to change. © Copyright Q-Audio. E&OE.



M A D E I N C H I N A

## RECEIVER FEATURES

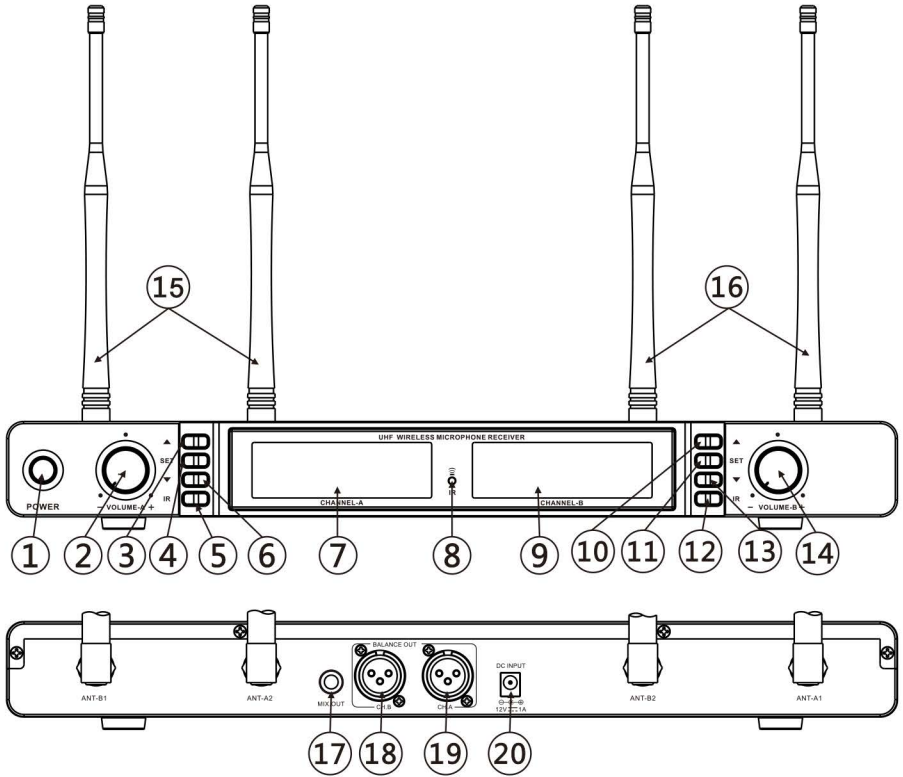

1. Power On/Off Switch
2. Volume Control A
3. Menu Up A
4. Function / Unlock A
5. IR Window A
6. Menu Down A
7. LCD Display A
8. IR Indicator
9. LCD Display B
10. Menu Up B

11. Function / Unlock B
12. IR Window B
13. Menu Down B
14. Volume Control B
15. Antennas for Channel A
16. Antennas for Channel B
17. Mixed 1/4" Jack Output
18. Balanced XLR Output B
19. Balanced XLR Output A
20. DC Power Input

## RECEIVER DISPLAY

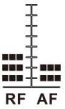
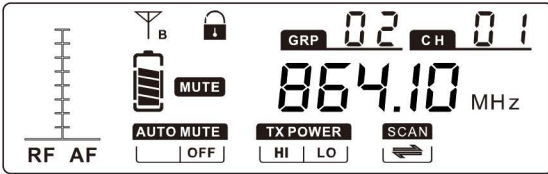

RF: Indicates wireless signal strength, the longer the bar length, the stronger the signal.  
 AF: Indicates audio level, the longer the bar length, the higher the audio signal.



True Diversity Antenna Symbol, indicates which antenna is being used to currently receive the transmitter signal.



The lock symbol indicates the receiver is in the locked state and settings can not be altered until unlocked.



The battery icon indicates the transmitter's battery status.



Frequency / Channel Indicators - GRP shows the current group, CH shows the current channel, the frequency of the GRP/CH selected is shown at the bottom in MHz.



Mute Status, the top mute indicator shows when the transmitter is muted. Auto mute (optional) shows when the auto mute setting is enabled or disabled.



TX Power indicates the wireless power level of the transmitter when synced.



Access the frequency scanning menu for finding free or less noisy frequencies.

## RECEIVER OPERATION

### GROUP, CHANNEL & FREQUENCY CHANGES

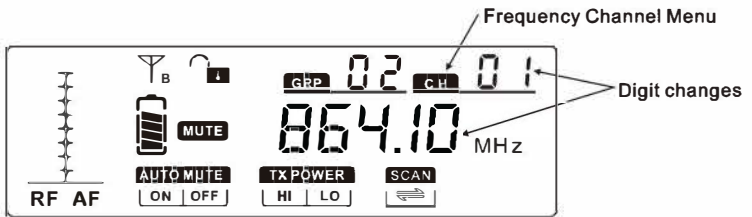
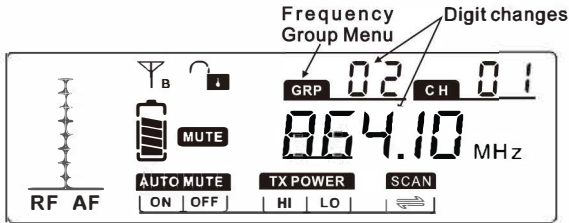

Changing the group or channel changes the frequency the receiver is set to receive (indicated above by digit changes)

### AUTO-MUTE AND TRANSMIT POWER CHANGES

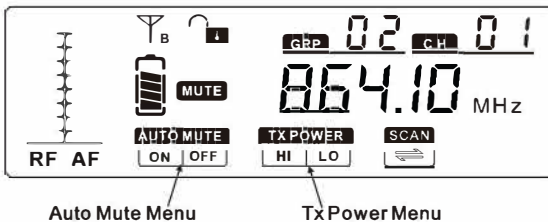

The transmitter power and auto mute settings can be changed here please note that you need to re-sync the transmitter when changing these settings

# RECEIVER OPERATION

## FREQUENCY SCAN FEATURE

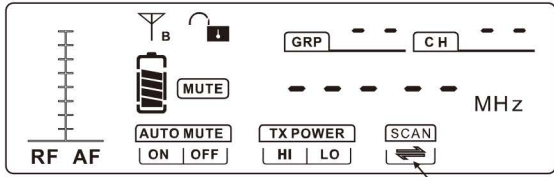

Enable the scan feature, the receiver will attempt to find the best available frequency with the least noise/interference.

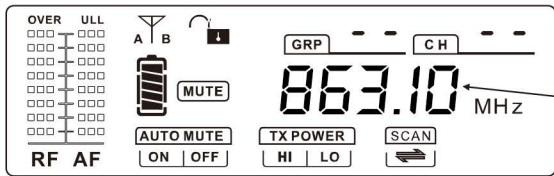

Once the scan has completed, the receiver will automatically change the receiver frequency to the channel with the least noise/interference (indicated above by digit changes).

After completing the scan feature you will need to re-sync your transmitter with the receiver channel you have just used to scan.

## HANDHELD TRANSMITTER FEATURES

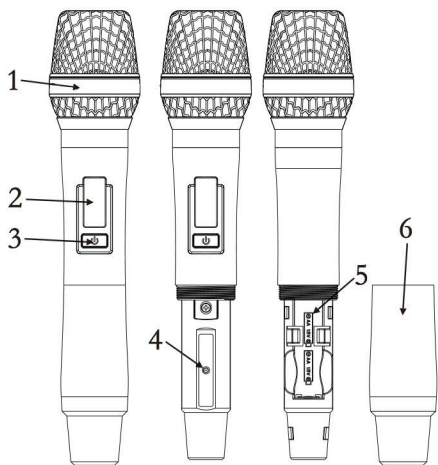

1. Microphone Capsule & Grille
2. LCD Display
3. Sync Window
4. On/Off/Mute Switch
5. Battery Compartment with internal indicator showing correct polarity
6. Battery Compartment Cover

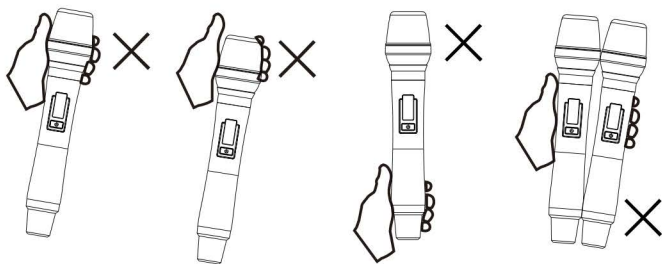

WRONG

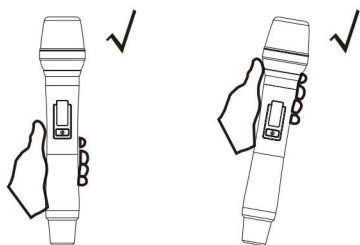

CORRECT

## BODYPACK FEATURES

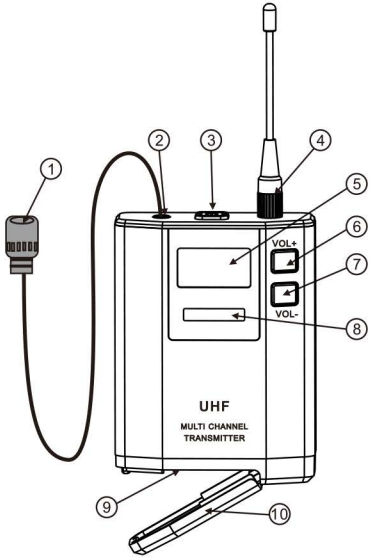

1. Microphone
2. Input Socket
3. On/Off Power Switch
4. Antenna
5. OLED Screen
6. Volume Up
7. Volume Down
8. IR Sync Window
9. Battery Compartment with internal indicator showing correct polarity
10. Battery Cover

The QWM 1970 bodypack transmitter features a TA4 (4 pin mini XLR input) socket so that you can connect a range of different input options to the transmitter.

Included as standard with each system that includes a bodypack is:

- 1x Headworn Microphone
- 1x Lapel Microphone
- 1x Guitar Cable

You can also connect microphones and input options from other manufacturers however compatibility is not guaranteed.



## QUICK START GUIDE

1. Connect power to the receiver via the DC input socket
2. Connect your chosen audio output to your mixer or speaker
3. Turn on the receiver via the power on/off button

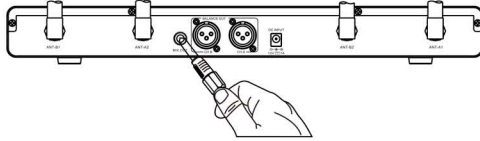

4. Turn on your transmitter(s), the frequencies should match the receiver display, ensure that only one transmitter is used with one receiver channel at a time. The RF indicators will indicate that the channel is receiving a signal.
5. Speak into the microphone, the AF level on the receiver should fluctuate to correspond with the audio level the transmitter is picking up,

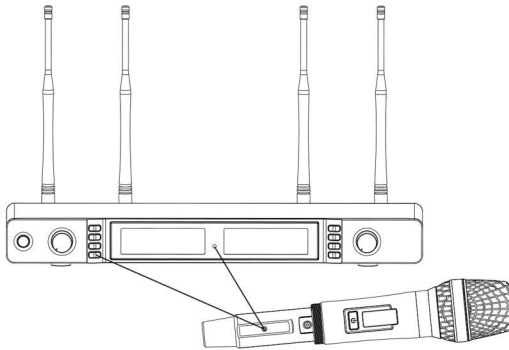

### IR SYNC

1. With the receiver powered on and unlocked, align the IR windows of the transmitter and the receiver.
2. Press and hold the IR button of the channel you'd like to sync for a few seconds
3. The receiver display will blink to indicate it is trying to sync to the transmitter
4. The frequency on the transmitter should change and the receiver will show an RF level to indicate the sync has completed.

*If the sync does not seem to take effect, power down the transmitter and wait a few seconds. Power the transmitter back on and re-try the above steps. Make sure the IR windows are aligned but have a small gap between them to ensure a good sync.*

## TECHNICAL SPECIFICATIONS

### Receiver:

**Frequency:** 863 – 865MHz or 606 – 614 MHz (See barcode)

**Bandwidth:** 2MHz or 8MHz (Frequency Dependent)

**Dynamic Range:** 96dB

**Distortion:** <0.1%

**Signal/Noise Ratio:** 96dB

**Frequency Response:** 30Hz – 20kHz  $\pm$ 2dB

**Signal/Noise Ratio:** 90dB

**Receiving Sensitivity:** -95dBm

**Power Supply:** DC 12V 1A

**Audio Output:** 1x Mixed Unbalanced 6.3mm Jack, 2x Balanced XLR

### Transmitters:

**Frequency:** 863 – 865MHz or 606 – 614 MHz (See barcode)

**Frequency Switching:** IR Sync

**Harmonic Radiation:** <-50dBc

**Output Power:** Up to 30mW

**Batteries Required:** 2x1.5V AA batteries

**Battery life:** >5h

## WARNINGS & CORRECT USAGE

- Where possible, place the receiver in open space, so that it can receive the best possible signal.
- Do not throw or mishandle any part of the system.
- Do not use any part of the system in the rain or under water.
- Keep all parts of the system away from direct sunlight and any forms of electromagnetic fields
- Make sure to insert the transmitter batteries in the correct orientation, and remove them from the transmitters after use.
- Turn off the transmitters and receiver before replacing batteries.
- Remove the power adapter from the receiver if it is not in use.
- Do not take apart any part of the system, no user serviceable parts are inside.
- Use a soft cloth to clean the system, do not use any fluids.
- Keep a space around the device for ventilation.
- Do not cover any ventilation holes.
- Do not put any part of the system near or on a fire or flame.
- Keep all parts of the system away from any form of liquid or dust.
- Do not mix new and old batteries. Always replace batteries in pairs and with the same type of battery ensuring to discard used batteries correctly as per recycling rules in your region.
- Working temperature: 5°C- 60°C.

### **Steps to prevent and overcome interference and audio issues when using wireless microphones:**

- Adjust the placement or direction of the antennas.
- Keep all parts of the system away from radios, TVs, phones and other devices that may have wireless signals or EMF.
- Do not plug the system into the same electrical socket outlet as a radio or TV.
- The handheld transmitter captures the best audio at an angle of 45° to the source, this helps prevent audible plosives and breath noise.
- Only pair one transmitter to one receiver channel, multiple transmitters to one receiver channel will cause interference and audio loss.
- Ensure that microphones are not placed more than 15cm away from the sound source to get the best possible pickup and frequency response. This system features cardioid capsules which are best for close range.

## UK FREQUENCY INFORMATION

The Q-Audio QWM 1970 system operates in the UHF frequency band. In the UK the frequencies this system uses are available to use on a 'shared basis'.

There are 2 frequency options available to the QWM 1970 system - Channel 70 (863 - 865MHz) and Channel 38 (606 - 614 MHz).

Channel 70 requires no license to operate wireless microphones within the frequencies. The channel 70 band is only 2MHz wide so only a small number of wireless devices can be used within that frequency band. For this reason we do not recommend operating 2 or more QWM 1970 systems together on channel 70 frequencies.

Channel 38 requires a license that is purchasable from Ofcom for a period of 1 or 2 years. Whilst a license is required, channel 38 is generally considered better than channel 70 as it has 8MHz bandwidth (4x more than channel 70) and it requires a paid license to operate, thus less people will likely use it. We recommend that no more than 3 QWM 1970 systems should be used in the channel 38 band, although results will vary in different areas and could result in more or less systems working together at one time.

Both frequency bands are used across the UK and different areas and regions have different may have different results in wireless operability. Both bands are used on a non-protected basis meaning that other users can use the same frequencies which may cause interference. Always check your frequencies before use to avoid any interference or unwanted audio transmissions.

At each end of the frequency bands, there are small 'guard bands' to help prevent overlapping interference due to deviation. In channel 70 we recommend using frequencies between 863.1 - 864.9MHz and 606.5 - 613.5Mhz in channel 38.

If you plan to use your QWM 1970 system abroad, please check that your system frequency is compatible with the country you are using it in. The QWM 1970 systems have been designed to be compatible with UK frequencies only; Operation in other locations is not guaranteed or recommended.

## USER NOTES

# Box Contents

1x QWM 1950 Receiver

2x Transmitters

1x 1/4" Jack Cable

1x Power Adapter

2x 1.5V AA Batteries

1x Manual